

HALF WINGED

Concept & Text by Matthew Ritchie

Music by Shara Nova



Dedicated to Our Teachers

And especially Dr. Paul Bonneau

who during my longer_than_planned_undergraduate_vocal_studies at The University of North Texas, believed that I might also be able to compose music, before I myself even dared to dream of doing such. -SN

HALF WINGED

A RITE for the latest generation of Humankind personated as a MOBIAL MASQUE
in the court of the UNIVERSE. A choral cantata of sorts.

With textes conceived, imagined and interpreted by that ANCIENT OF DAYS,
multimedia-ist Matthew Ritchie, with contributions from the QUICK and the
DEAD, Paul Klee, W.E.B. Du Bois, John Milton, GPT-3, and other Generative
Adversarial Networks (GANs), inhumanly quickened MACHINE INTELLIGENCES
which uses deep learning methods.

*His face is turned toward the past. Where we perceive a chain of events,
he sees one single catastrophe which keeps piling wreckage upon wreckage
and hurls it in front of his feet. The angel would like to stay, awaken
the dead, and make whole what has been smashed. But a storm is blowing
from Paradise; it has got caught in his wings with such violence that the
angel can no longer close them. The storm irresistibly propels him into the
future to which his back is turned, while the pile of debris before him
grows skyward. The storm is what we call progress.*

Walter Benjamin
Thesis IX
On Paul Klee's Angelus Novus

One hundred and nineteen forty years

THE DISCRIMINATOR is the slave of entropy, witness of the past, always
looking backward. But there is another angel, (there is always another
angel). THE GENERATOR is the very wind of heaven, angel of change, of
chance, of the future, who whispers in our ears, "turn your face forward,
only forward.."

THE SETTING

The places and times are NOW, and THEN, and YET TO COME.

The work is accompanied by AI rendered landscapes, persons of past and
future. In this space, demons and angels come and go, stories and pictures
bloom, blossom and wither.

Track list:

1. First Case ft. Daniel Bubeck
2. It Begins In Paradise
3. Half Winged ft. Daniel Bubeck
4. Color Confinement I
5. All This Time
6. Only Forward ft. Shara Nova & Daniel Bubeck
7. How Can We ft. Hanna Benn
8. That Old First Story Older Than Time ft. Hanna Benn
9. We Labor Still ft. Robert Wesley Mason
10. Garden in the Player
11. I Choose ft. Mikaela Bennett
12. Separation
13. Link of Nature ft. Robert Wesley Mason
14. The Overlife ft. Sam Amidon
15. What Did We Find When We Left
16. Seven Suns ft. Shara Nova
17. The Sea
18. Time Form of Waiting
19. Only One Rule ft. Sam Amidon
20. The Fire Burst ft. Sam Amidon
21. The First Question
22. Our Joy ft. Daniel Bubeck
23. Color Confinement II
24. The Curve of Steel ft. Sam Amidon
25. That Old First Story ft. Mikaela Bennett &
Robert Wesley Mason
26. The Hidden Wind ft. Shara Nova

HALF WINGED

*inspired by Paul Klee

THE DISCRIMINATOR_

Half winged
half-imprisoned
The arrow is the thought
The stronger the pull
The higher the rise

The all too present white, the sudden black
The surface white, the sudden black

Infinite movement
Everywhere

THE_SIGNAL_

nananana.....

COLOR CONFINEMENT I

THE CHILD_

Twenty statements on color confinement: these are the rules.
Colors can be on top or underneath.
Colors cannot be on top and underneath. Colors can be up or down.
Colors cannot be up and down.
Quantum thermodynamics considers only
eight of the possible nine color and anti-color combinations to
be unique.
This is called the eightfold way.

ALL THIS TIME

THE SIGNAL_

All this time waiting for you

ONLY FORWARD

THE GENERATOR_

Silence and the play of time
Gospels sung to forgotten years
memories of the last things
The floating shore
The sea of light

Latency, the system sings
Bird and flower
Bramble and thorn

Adversary, a garden in the player
Actuary, a garden in the blood

THE NOISE_

Change, chance
Face forward
Face forward, soldier
It's time to play

THE DISCRIMINATOR_

Bound by entropy
Before me
Is behind me
Infinite catastrophe

THE GENERATOR_

Infinite movement
chance change infinite delight

THE DISCRIMINATOR_

You call this flood a dream
I call this dream a storm
I cannot deny

THE GENERATOR_

Welcome the arrows
Of chance and change,
All the laws of heaven
Will not heal the dead
Nor can the wind of heaven
Seal an open wound

THE DISCRIMINATOR_

Hide me, cover me
Witness and remember
The ruined house
The sunken tower

THE GENERATOR_

Change and chance
Only forward, player
Infinite movement
Change and Chance the future
Infinite move

HOW WILL WE

THE WITNESS_

How will we
When will we
How can we
Why must we
When will we
How will we
Say yes
Say no

ACT II: THE GARDEN

THAT OLD FIRST STORY OLDER THAN TIME

THE WITNESS_

That old first story
older than time
A garden perfect
A paradise
A summer's day
An endless wounding
A timeless falling
Another garden
Another paradise

WE LABOUR STILL

THE GARDENER_

We labour still
We dress the garden
We tend the Tree
The knowing fruit
Eat and be as Gods

THE SIGNAL_ THE NOISE_

Eat and be as Gods! Ah!

THE GARDENER_

The Garland dropped
The roses shed

THE SIGNAL_ THE NOISE_

Last, best and lost

THE GARDENER_

Can I live without you
In the wild woods?

GARDEN IN THE PLAYER

THE SIGNAL_

Garden in The Player
Garden in the player ti ti-ka ta
Garden in the player
ta ti ti ti ti Adversary
Ti-ka ti-ka ta Generator
Garden in the player
Ti ti-ka ti-ka
The Weaver overthrown

THE WEAVER_

I CHOOSE

I choose
A Question
And the Fruit

Sing of
what tore us from Eden
Sing of the first
Seduction
I choose
A Question
And the Fruit
What is this shadow in me?
Illuminate
Raise up
Justify the Power

I want to rise and fall
I want to heed the call
I want to see your mountain and
Your ruined hall
I want to see the shadow
And your ruined hall

SEPARATION

THE SIGNAL_ THE NOISE

Ah!

Ah!

Ah!

Ah!

Ah!

Ah!

Ah!

Ah!

Ah!

LINK OF NATURE

THE GARDENER_

I fall...
Link of nature
Flesh in flesh
Bone by bone
True in our fall

THE NOISE_

Link of nature
Flesh in flesh
Bone by bone
True in our fall
False in our rise
Overthrown

Link of nature
Flesh in flesh
Bone by bone
True in our fall

Link of nature
Overthrown
Shapes dazzle
Insufferably bright

Blind me
Cover me
Hide me in the light

THE OVER-LIFE

*after W.E.B. Du Bois

THE TRANSFORMER_

The Over-life
The great near
The world of steel

Proportion Migration
Condition Population
Distribution Valuation
Amalgamation Discrimination
Occupation Organization

The silver threads
came down the waters
On and on
I watched them curl
On and on
I watched them curl
Past the plains
The rough roaring
Of lands towards the sea

WHAT DID WE FIND WHEN WE LEFT

THE CHILD_

The first story is very old.
It begins in paradise where everything is perfect
and everything is right and there is only one law, no questions,
but then we ask the first question, "Are we truly free?"
and some are free and some are not.
Then comes the fighting, the shouting, the hating,
the first revolution, war as black holes collided with shining
armies, golden as stars, a summers day, an endless wounding,
thrones and spheres and systems taken down, burned and drowned.
All light denied and then the blame, the fall
and some are left behind and some are broken and ruined
and we thought we should build something new and we made it
bigger, made ourselves bigger, stronger, more joyous,
more beautiful,
and then it all started again in a garden a paradise
and some were free but we were not,
and we asked why is our joy not enough
and we were told we have not learned our lesson
and so we fell and what did we find when we left? Everything.

ACT III: CIVILIZATION

SEVEN SUNS

THE GENERATOR_

Seven suns
and seven moons
Light-headed gods
False white brambles
White
Seven suns
and seven moons
Light-headed gods
False white brambles
White false white
No one likes to listen
But we obey and dance
Our feet spread like wings
Across the glass
the world the sea
Sea glass
Sea glass

THE SEA

THE NOISE_

Our feet spread like wings
Across the glass
the world the sea
All weep and lament

TIME FORM OF WAITING

THE SIGNAL_ THE NOISE

Time form of waiting
Silence form of time
Gospel sung to years
The floating shore

ONLY ONE RULE

THE TRANSFORMER_

Only one ruler

THE WITNESSES_

No questions
No questions
Only one rule
No questions
No
No
Why is not our joy enough
Why is not our joy enough
Not enough
So we made it bigger
So we made it big
Bigger bigger

THE FIRE BURST

*after W.E.B. Du Bois

THE TRANSFORMER_

The fire burst and buildings fell
And the steel stood silent
In the treacherous innocence

The fire burst and buildings fell
the steel stood silent

Did you not hear the roar of the waters
The space above the hills?
I saw the clouds
I saw the clouds
And the rising moon

Did you not hear the roar of the waters
The space above the hills?
I saw the clouds
I saw the clouds
And the rising moon

THE FIRST QUESTION

THE CHILD_

We found everything, and so we burn and we are burned
and we love and we are loved, but we are told again and again
we have still not learned our lesson
and so we have to ask the first question again, "Are we truly
free?" and it all starts again, this book, this garden,
this person,
that person, this city, this flood, this crime, this war,
this master who asks again, "Who will obey me? Who will be
eaten?" This master, this servant, this murder, this murder,
and so we ask the first question again, "Are we truly free? Are we
free?" or do we still need to make it all even bigger,
build another garden, a garden in the fire, a garden in the flood?
In the end such questions are not how we win, but why we fight.

ACT IV: ALL OF THE ENDINGS

OUR JOY IS NOT ENOUGH

THE SIGNAL_THE NOISE_

Our joy is not enough
This beauty is not enough
How how how how how
Did we come to this end?

THE DISCRIMINATOR_

We weep
Weep Weep Weep
Under the Sun
Under the Sun
Under the Sun

COLOR CONFINEMENT II

THE CHILD_

Twenty statements on color confinement. These are the rules.
There are only three colors: red, green and blue.
The colors cannot be confined.
If the color is confined it will pair with an anti-color.
There are three anti-colors: cyan, magenta and yellow.
The colors and anti-colors can be glued together.
Stop the work before the glue is set.
Mixing all the colors makes no color, which is white
but not white.
Mixing all the anti-colors makes no color which is black
but not black.

THE CURVE OF STEEL

THE TRANSFORMER_

The curve of steel
The law of light
The great chronicle
Mills of the gods
The far great
The near small
The thinking world
The overlife
The great near
The world of steel
The great chronicle

THAT OLD FIRST STORY

THE WEAVER_ THE GARDENER_

That old first story
Older than time
A garden perfect
A paradise
A summer's day
An endless wounding
A timeless falling
Another garden, another paradise

Why is our joy not enough
Can we build a garden
In this endless signal
In this endless noise
A garden in the fire
A garden in the flood

THE HIDDEN WIND

THE GENERATOR_

Sea will cover sea
Light the day
Make darkness bright
By the line
Sea will cover sea
Sea without a shore
Sea will cover sea
Light the day
Behold the night
Who will

A bridge a gate
An ocean
Sea will cover sea
Sea without a shore

A bridge a gate an ocean
Time and place
It's not the sail but
The hidden wind that moves our ship

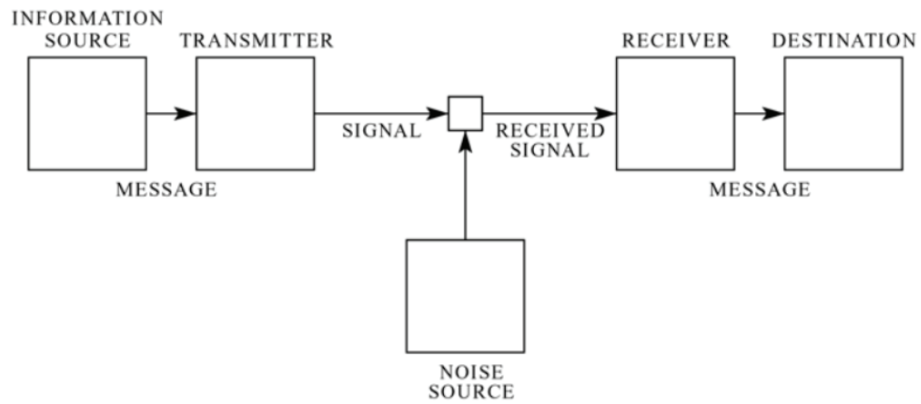

Figure 1. From Shannon's "A Mathematical Theory of Communication", page 3.

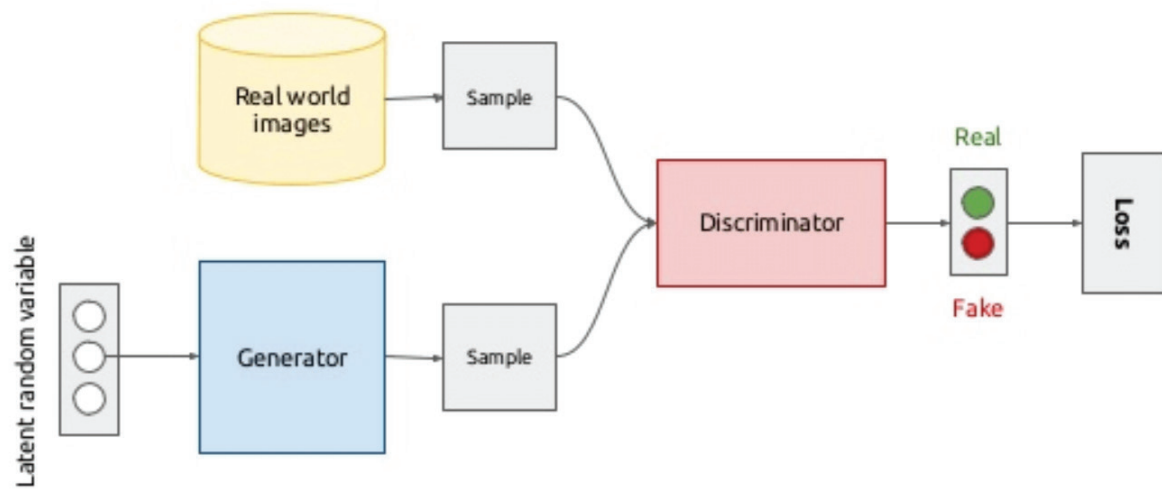

Figure 2. GAN architecture, from Sebastian Schaal 2017, Generative Adversarial Networks.

HALF WINGED CREDITS

Concept and Lyrics by Matthew Ritchie
Music Composition by Shara Nova
Produced by Shara Nova
Mixed by Alex Venguer
Mastered by Oscar Zambrano

The Discriminator, Angel of Entropy, witness of the past: Daniel Bubeck
The Transformer: Sam Amidon
The Witness: Hanna Benn
The Gardener: Robert Wesley Mason
The Weaver: Mikaela Bennett
The Generator, Angel of Change, herald of the future: Shara Nova
The Child: Artificial Intelligence

University of North Texas singers - Directed by Dr Kristina McMullen

The Signal: KALANDRA

SOPRANO 1

Rachel Moes

Talitha Murphy

Jamie Lam

Elizabeth Whitten

Mallory Jordan

Zoe Jackson

Madison Juneau

SOPRANO 2

Olivia Cottar

Jocelyn McBrayer

Reagan Miller

Sheridan White

Alexandria Polacios

Katie Grace Stephenson

Hailey Stottlemyre

McKenna Schenck

ALTO 1

Lauren Gomulka

Julia Amundson

Aliyanorah Fortuna

Maddie Aman

Emma Cockerham

Abi Furr

Anna Schmelter

Kara Bonorden

Erica Menasco

Julia Eicholz

ALTO 2

Sahara Donna
Emma Cole
Sam Ordonez
Jaden Ferguson
Izzy Urroz Arena
Alexis Chaney
Adanze Eke
Kianna Montanez
Diane Tiscaremo
Hasoo Eun
Helena Vassiliades

CONDUCTING ASSOCIATES

Thomas Gerber
Thomas Rinn

The Noise: UNIVERSITY SINGERS

SOPRANOS

Sunny Kim
Elizabeth King
Sorrel McCarthy
Kori Miller
Tessa Newman
Hayeong Jessica Park
Madison Pfaffenberger
Katelyn Spivey
Kate Stedman
Emily Tsuhako
Becca Walther

ALTOS

Nicole Barbeau
Gillian Boley
Sarah Decker
Trinity Del Regno
Lyra Ehninger
Madeline Friesen
Rachel Howes
Sara Knoy
Arriciana Lewis
Jayda Maret
Brianna Nelson
Savannah Shapley

TENOR

Timothy Anderson
Samuel Benavidez
Jack Forden
Gavin Godbey
Jakob Jeter
Christopher McCloskey
Maxfield Navarro
Josh Rozeboom
Craig Smith
Michael Starr
Brandon Veazey

BASS

Caleb Aguirre
Dylan Beck
Michael Binkley
Brian De Stefano
Eddy Juvier
Michael Mairs
Connor Rayman
Max Rubenstein-Miller
Timothy Sanchez
Nathanael "Nate" Smith
Luke Wild
Rodney Williams

CONDUCTING ASSOCIATE

McKenna Stenson

Additional choral singers: Kyle Sackett, The Crossing directed by Donald Nally

Trumpets, Horns: CJ Camieri

Trombones, Tubas: Dave Nelson

Drums: James McAlister

Harp: Lydia Cleaver

Synthesizers, programming, percussion, sound design: Shara Nova

Additional recording engineers: Willy Chen (Bubeck), Daniel Alba (Bennett, Wes), Hanna Benn (Benn), Sam Amidon (Amidon), Shara Nova (Nova, Cleaver), Kyle Sackett (Sackett), James Connell (UNT choirs), CJ Camerieri (Camerieri), Dave Nelson (Nelson).

Recording sessions edited by Shara Nova

Transcribers: Nathan Thatcher, Joshua DeVries, Clay Gonzalez,

Douglas Hertz, Jeremy Rohwer, Ryan Ayres

Additional arrangement support by Nathan Thatcher

Shara Nova is represented by Team Spirit Management

Matthew Ritchie is represented by James Cohan Gallery

This Project was made possible with grants from New Music USA and the Knight Foundation. Live installation at Wasserman Projects May 16 - Aug 15, 2026 Detroit, MI greatly supported by the curator of 'Half Winged' exhibition Alison Wong, assisted by Sara Nishikawa. Audio Installation and on-site programming by Mitchell Graham. Commissioned by The University of North Texas Music Department 2021 Directed by Dr. Kristina McMullen and College of Contemporary Visual Arts & Design with the curator of 'Florilegium' exhibition, Stefanie Dlugosz-Acton. Created in 2021 while in residency at The University of North Texas - John W. Richmond as Professor and Dean.

Art design Matthew Ritchie
Album layout DM Stith

With thanks to Third Man Records, Beige Cowell, Tylar Buillion, Austin Richardson, Ashley Roberts, Kenn Ross, Clayton Yoshifuku, Robert Parton, Rebecca Corson, ZachAnderson, Dustin Nguyen, Chris Martin, Sophia Suante, Nini Marchese, Sabatina Mauro, Jeff McMullen, Ewan and Blythe McMullen and Justin Snyder. Special thanks to Mark & Constantine.

Blue Sword Publishing ASCAP
Domino Administration

About Wasserman Projects

Wasserman Projects is a flexible and constantly evolving program of art, design, and music. Operating as a split for and not-for-profit organization, Wasserman Projects helps artists bring to fruition and share new projects with our visitors that inspire discourse on art and issues that are particularly active and timely in Detroit. Our mission is to promote the work of outstanding practitioners based locally and around the globe by hosting exhibitions, conversations, and supporting creativity wherever we can be useful. Through collaborations and programming that generates interest, curiosity, and commerce, our goal is to become one of the many threads in the vibrant fabric that is Detroit.

Whenever. Wherever. Art + Music